



montage instructies
instructions de montage
assembly instructions
montage anleitung

VIC

BKO

! Sticker niet verwijderen (EN 12221-1)
! Ne pas enlever ce collant (EN 12221-1)
! Don't remove this sticker (EN 12221-1)
! Aufkleber nicht wegnehmen (EN 12221-1)

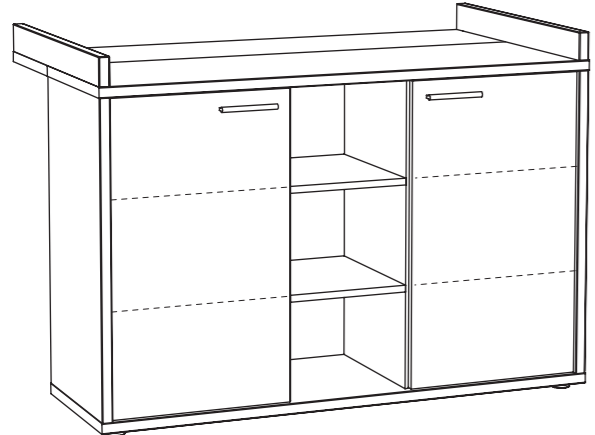

BKO 136 x 89 (97) x 44 (76) cm

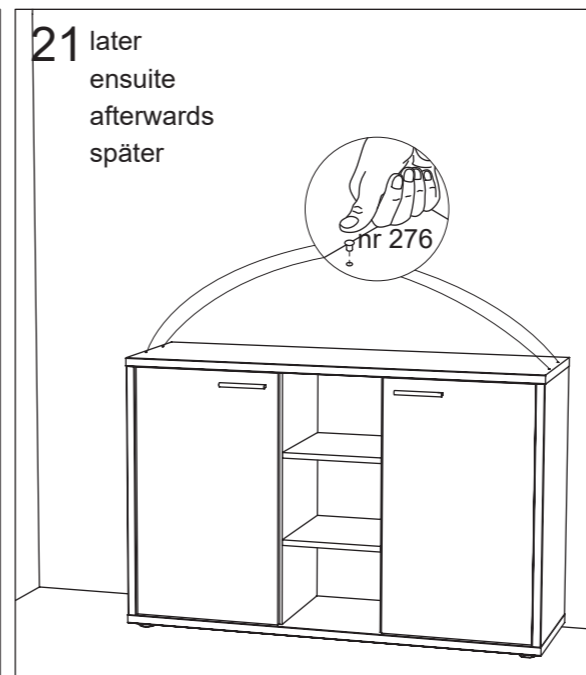
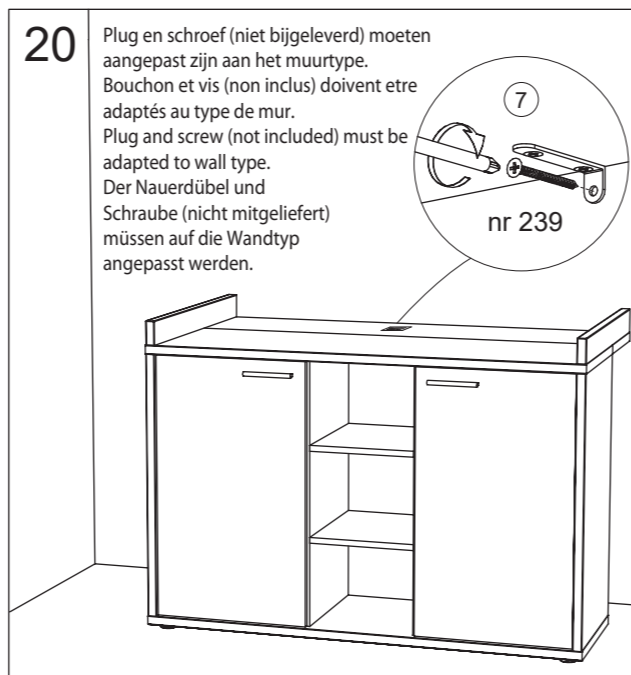
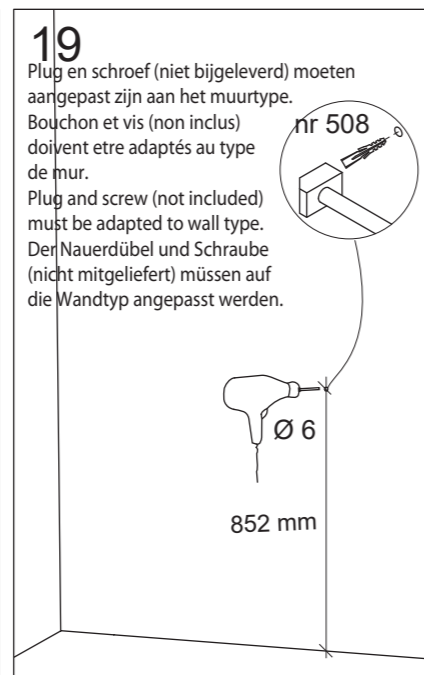
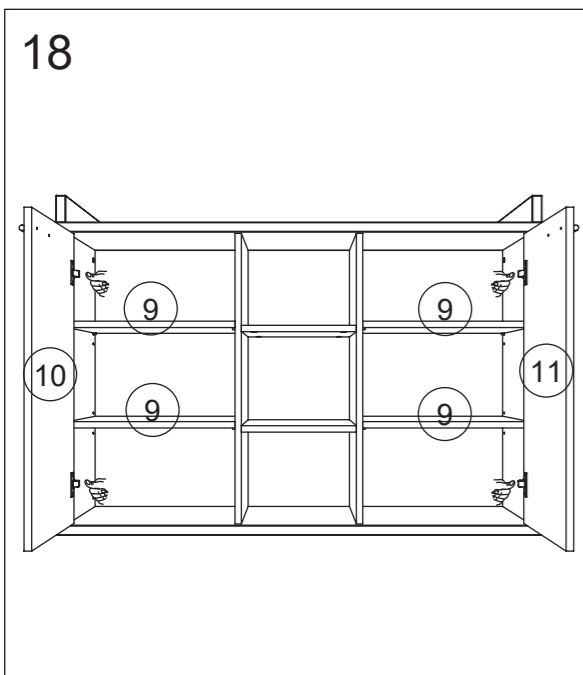
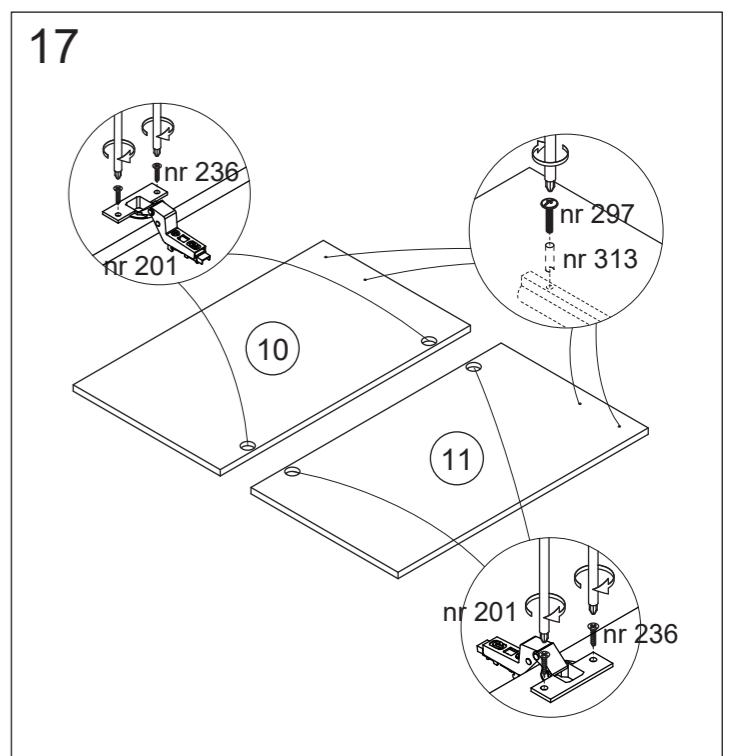
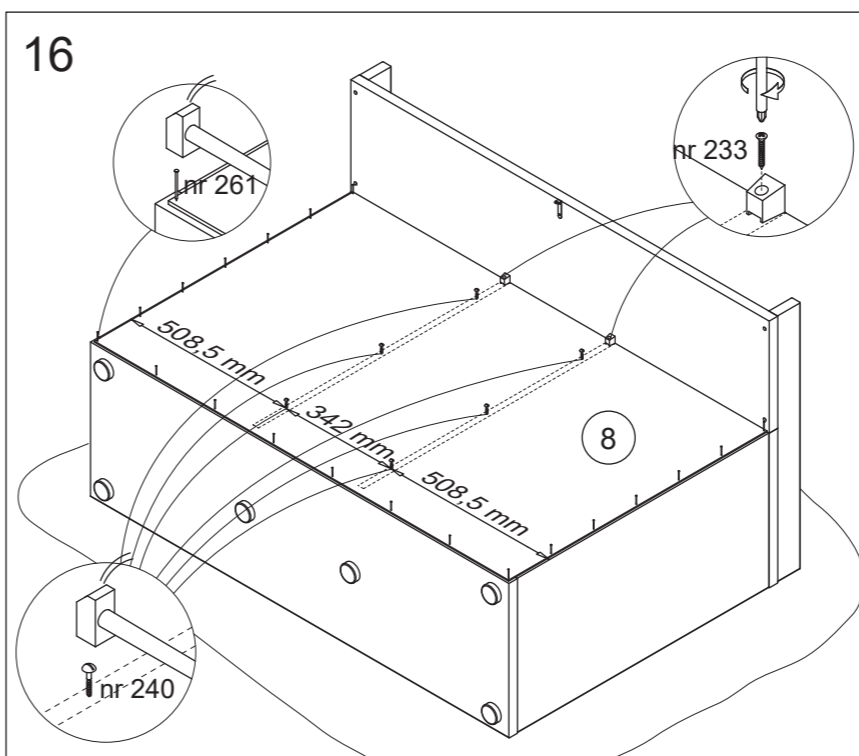
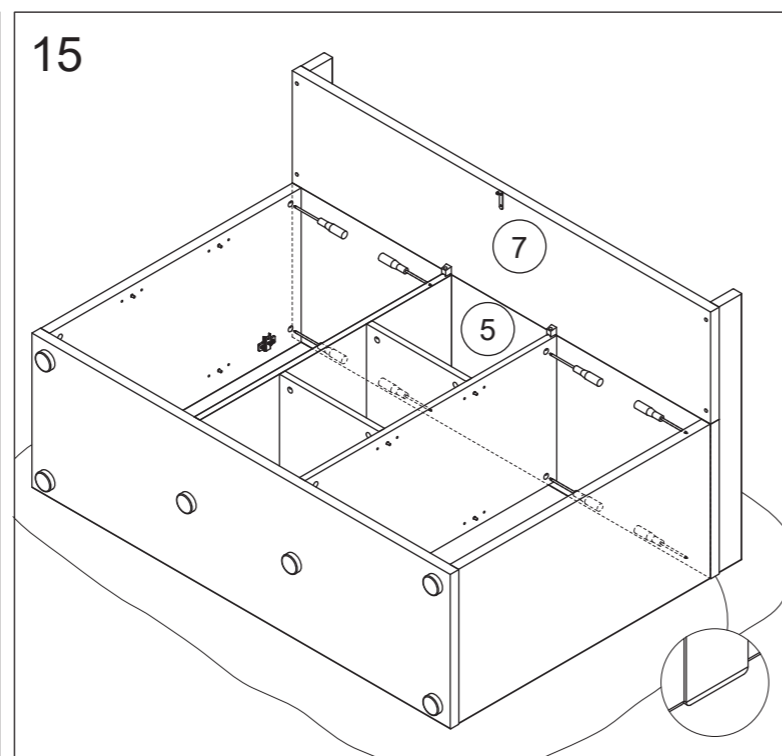
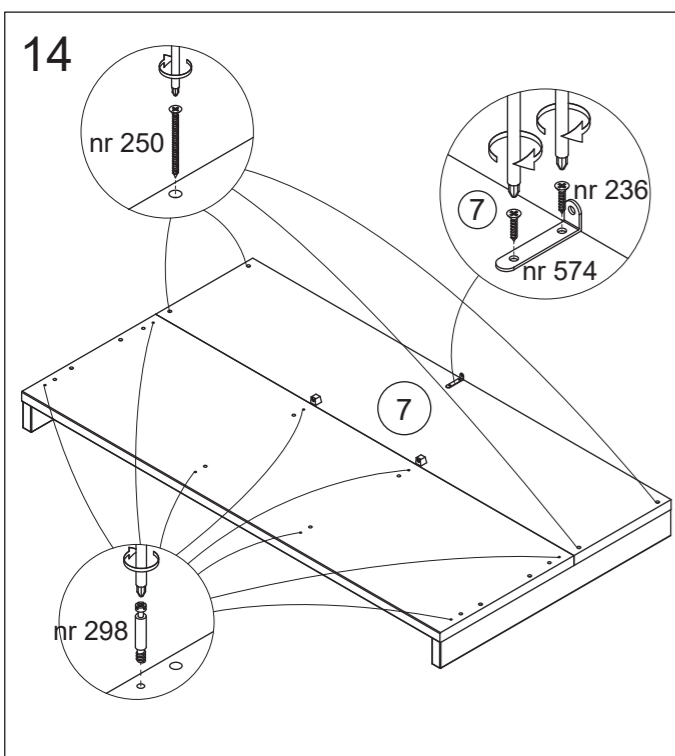
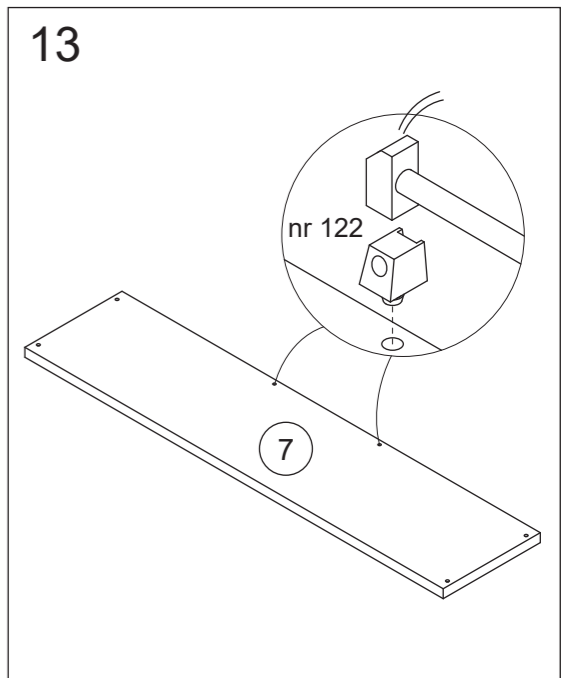
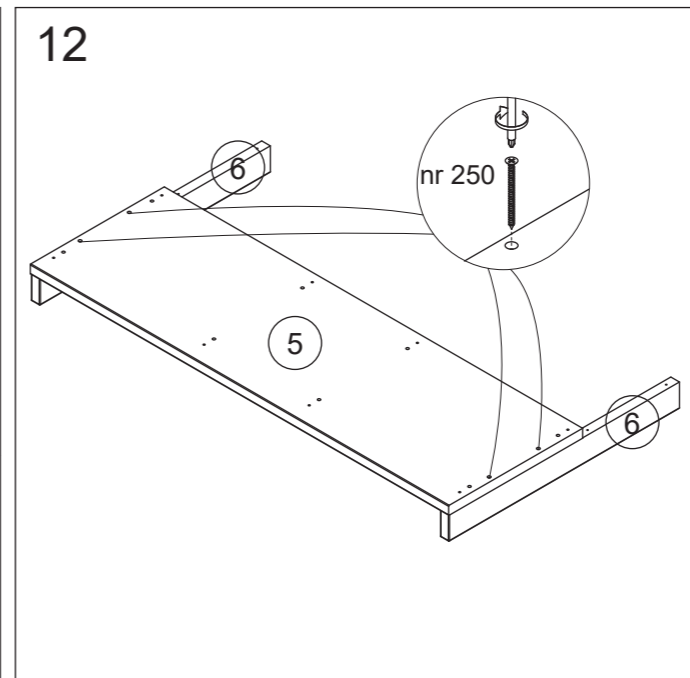
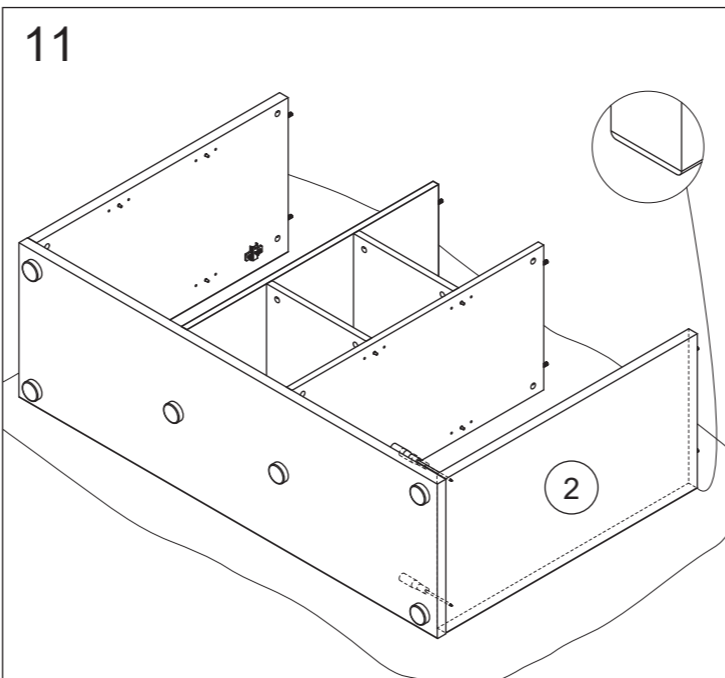
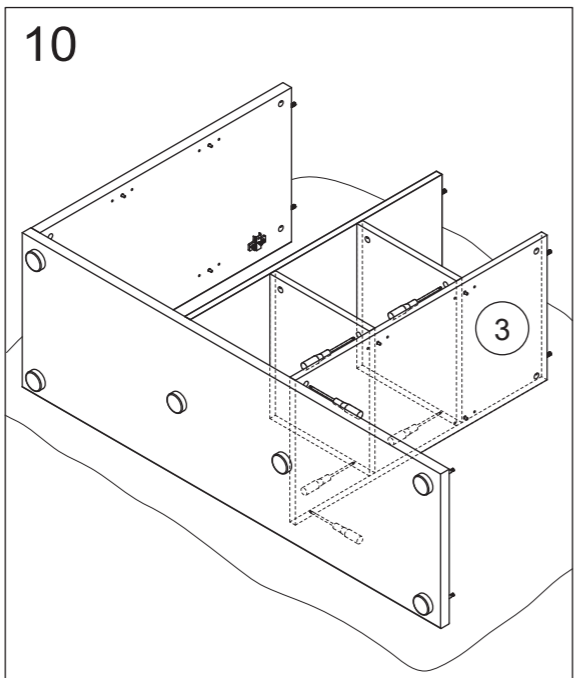
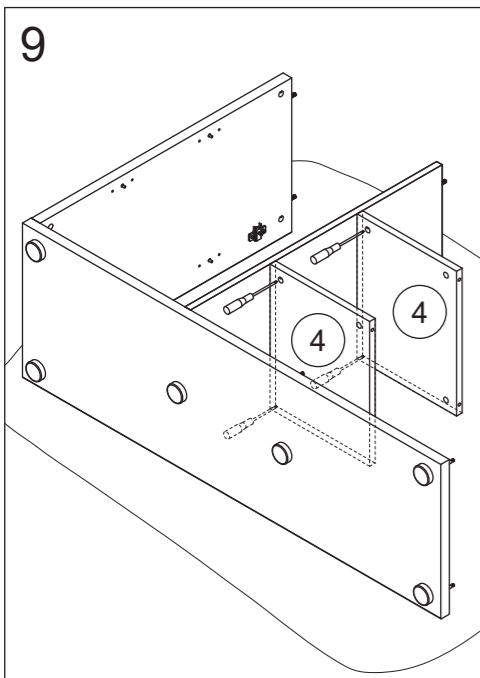
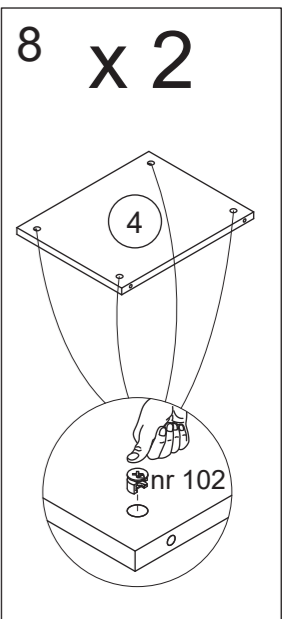
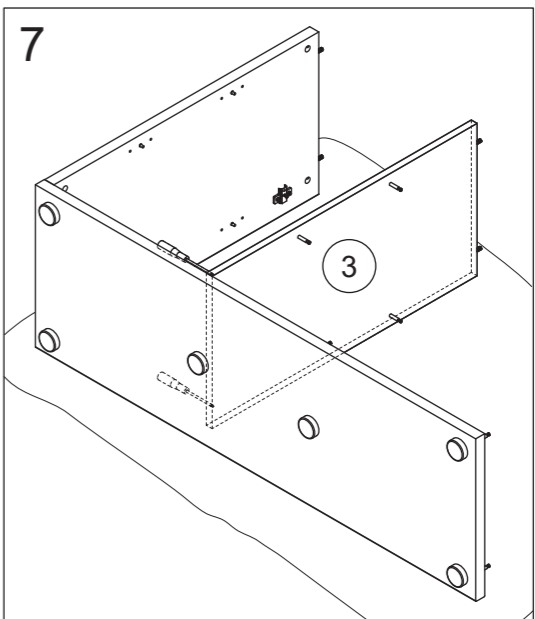
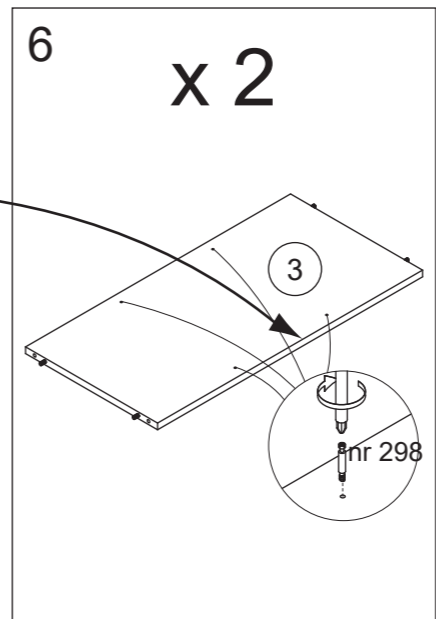
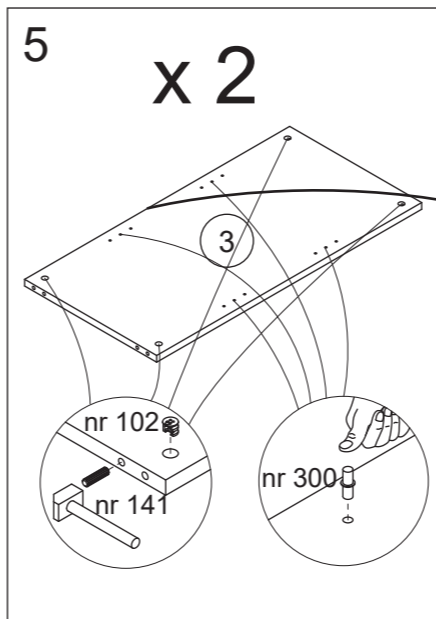
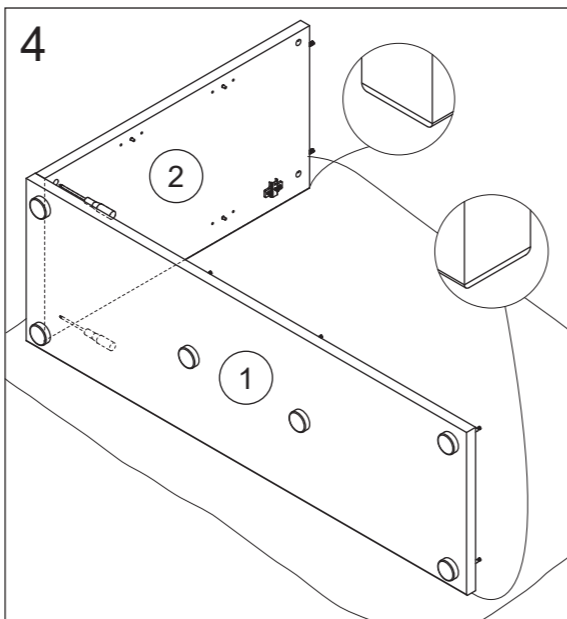
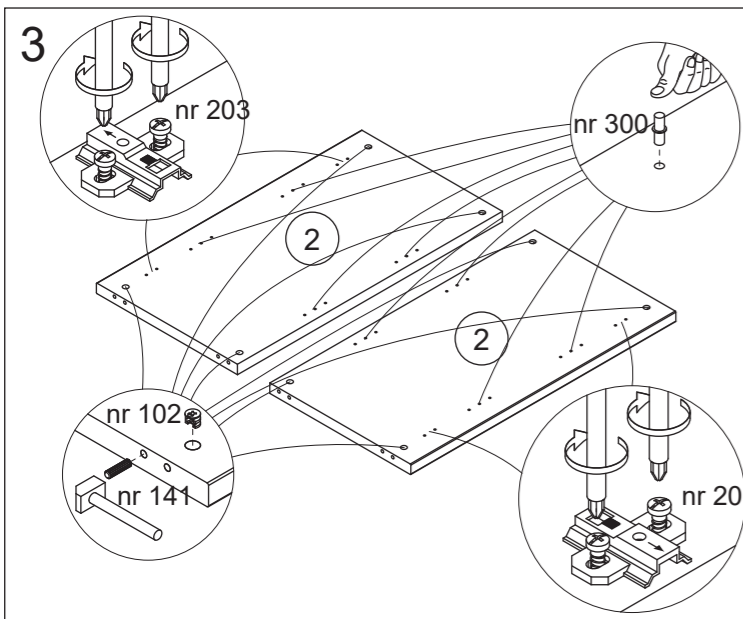
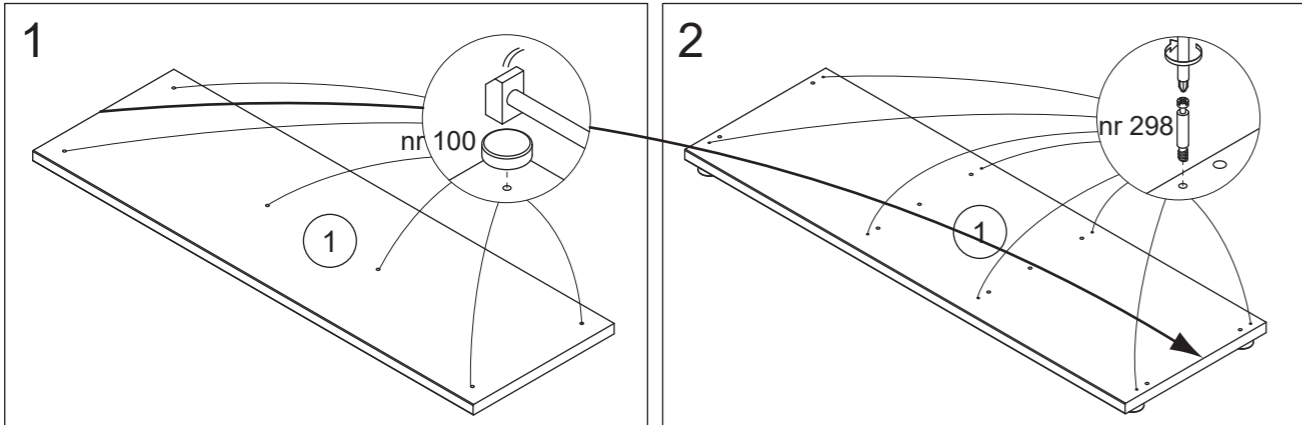

Voor de juiste regeling van de deuren moet U ervoor zorgen dat de kast goed waterpas staat, ook kunt U met de schroeven van de scharnieren 201 de deuren bijregelen. U kan ook de deuren vertikaal bijregelen. Ontspan vijzen A en schuif de scharnierblok nr. 203 naar onder of naar boven en schroef terug vast.

Pour un réglage des portes, l'armoire doit être de niveau, vous pouvez aussi régler les portes avec les vis des charnières 201. Vous pouvez aussi régler les portes verticalement. Dévissez vis A et glissez le blocque de charnière n° 203 en bas ou en haut et vissez de nouveau.

For the adjustment of the doors, the unit has to be at level, you can also adjust the doors with the screws of the hinges 201. You can also adjust the doors vertically. Unbend the screws A and slide the hinge block nr. 203 down or up and tighten again.

Für die richtige Regelung der Türe soll man darauf achten daß der Schrank waagrecht steht, auch können Sie mit den Schrauben der Scharniere 201 die Türe regeln. Sie können auch die Türe vertikal regeln. Schrauben A entspannen und der Scharnierblock Nr. 203 nach unter oder nach oben verschieben und wieder festschrauben.

